

Dear customer, I hope you enjoy this kit of a 1908 LSWR shunters wagon in 7mm. Below you will find the instructions for said kit. Overall, it is very simply, needing only a few things to glue together, as you can see on the diagrams. Diagram 1 shows the main body of the wagon with all the separate bits that go on to it. Everything can be superglued on as you see fit, or of course kept separate for painting if you wish.

In Diagram 2 you will see the main base of the model including the single brake block. Here you will use the smaller length pair of brass rod, inserted into the large knobs which will be located as shown.

Next, in Diagram 3, you can see how the longer of the pairs of brass rod go together. You should have a bit extra so you may wish to snip the ends a little to ensure that it is around the correct length.

Finally in Diagram 4 & 5, you can see the route I'd take to mount the buffers using the included wire. The first thing you want to do, is cut the wire in half, next you will turn the buffer so that the hole is facing up. Once this is done you can feed the end of the wire in and turn the buffer back around so that you can feed it through the other side. If the wire is too long you can snip it slightly, or what I like to do is put a bit of a kink in it, this also helps with feeding it into both sides, as it is a bit of a tight fit.

For painting I'd recommend Phoenix Precision's 'SR Freight Brown' for the main colour, and then whatever black and white you wish to use for the footboards and handrails.

Then for wheels, I'd recommend the slaters 3ft 1inch 8 spoke wheels.

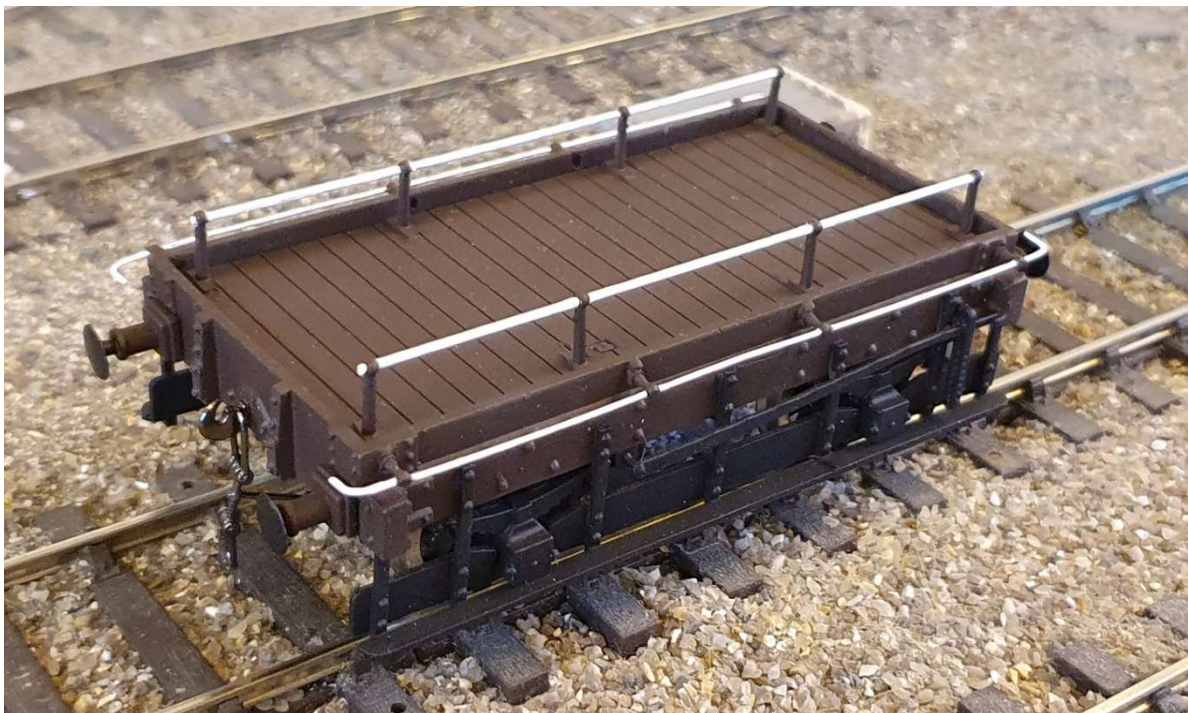

Diagram 1

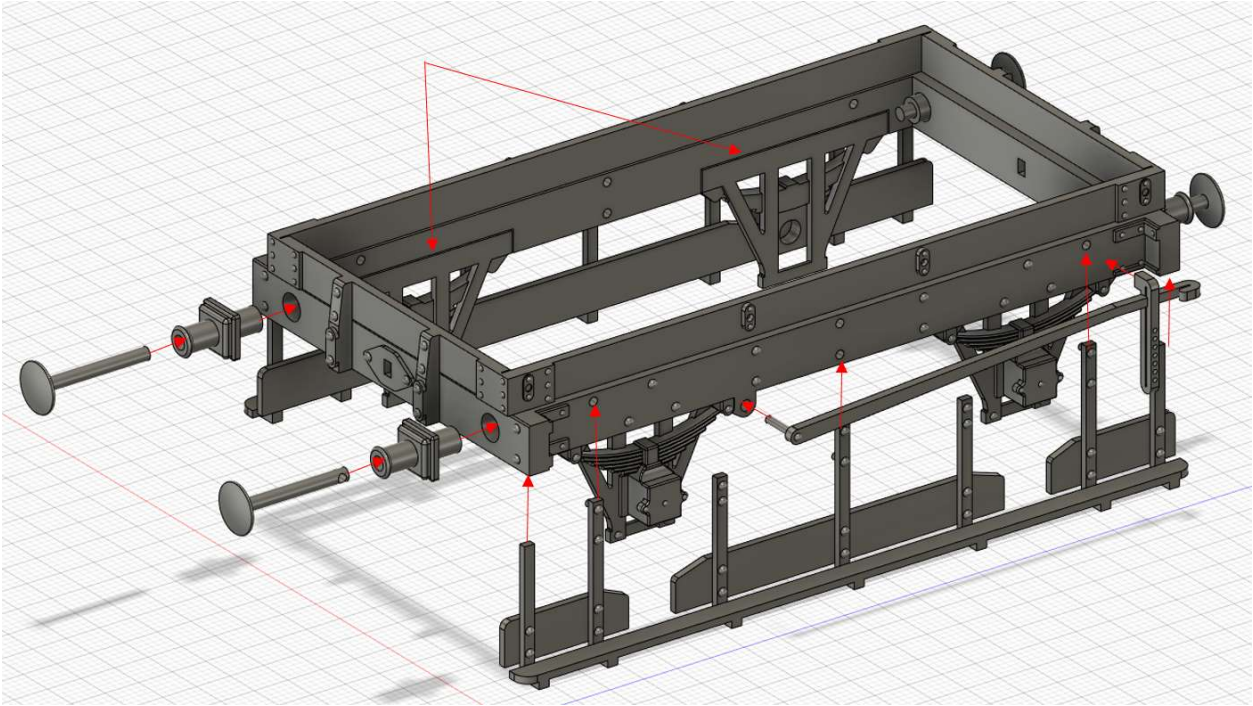

Diagram 2

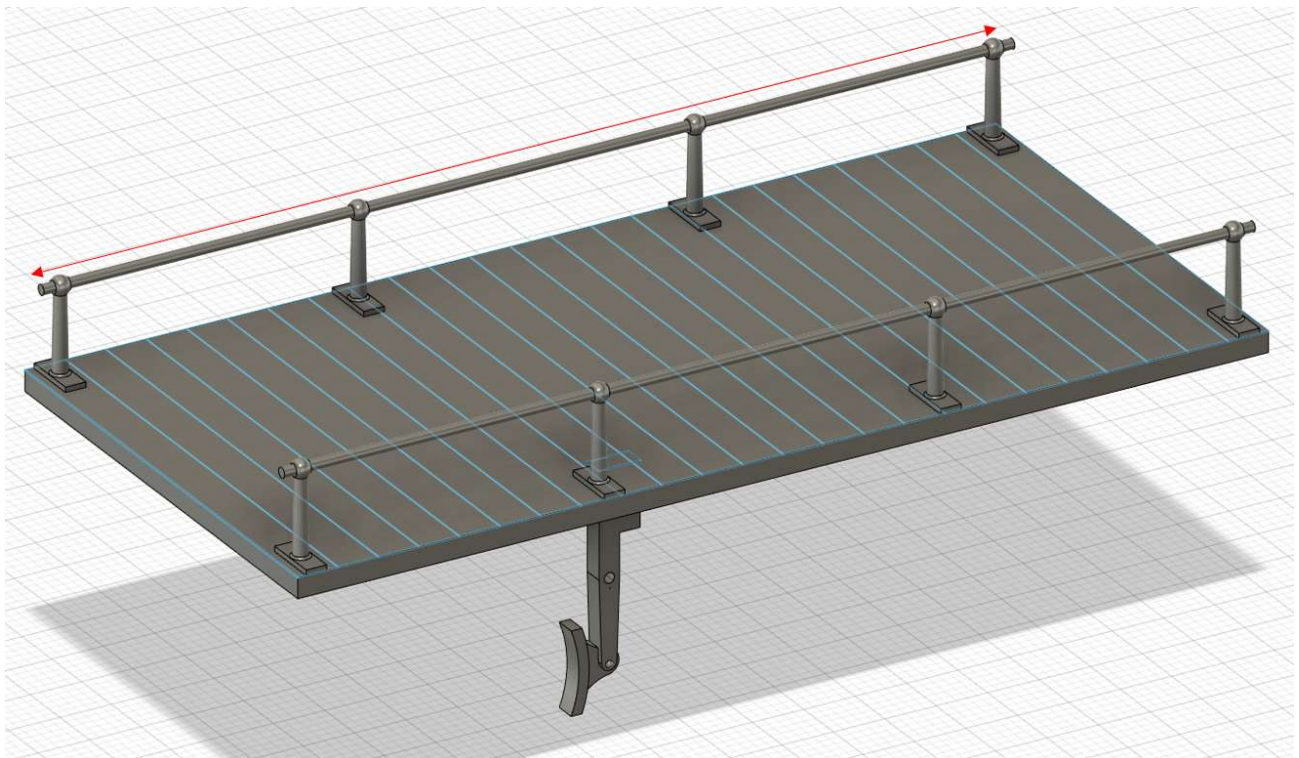

Diagram 3

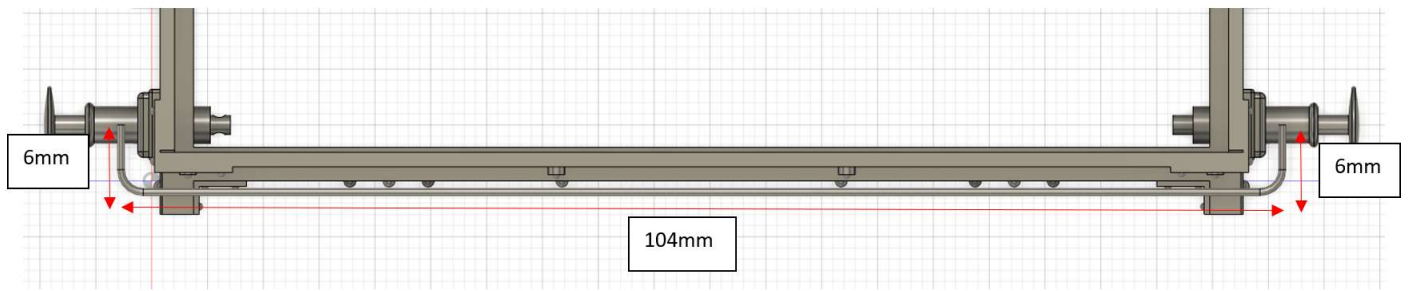

Diagram 4

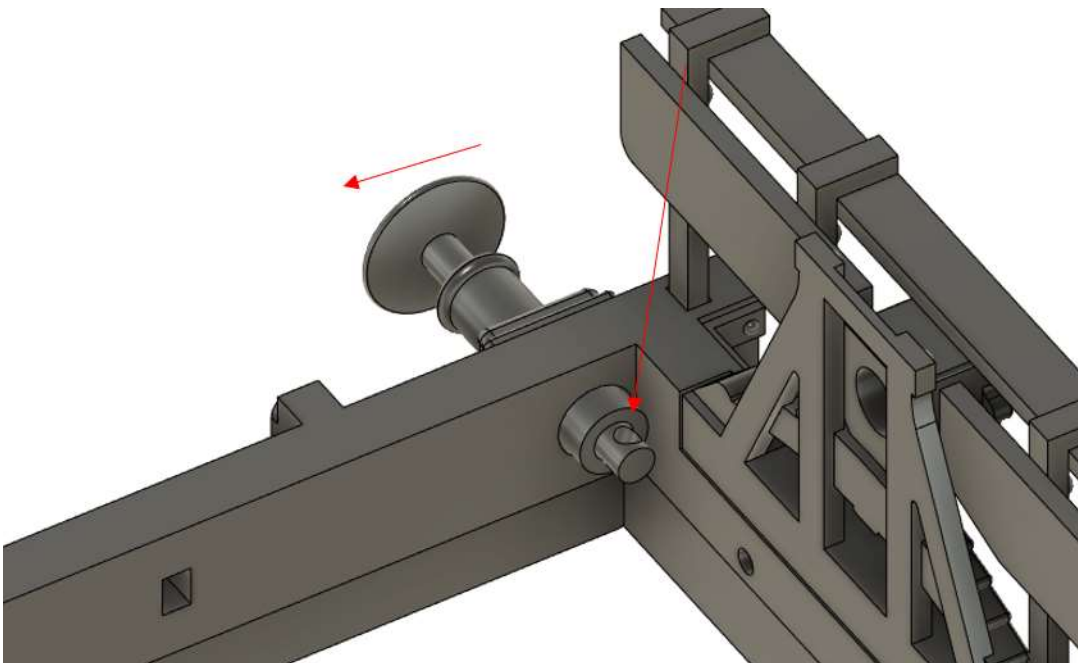

Diagram 5

